

Filter Design ENEX 301

Year/Part: III/I

Teaching Schedule				Examination Scheme						Total
L	T	P	Total	Theory			Practical			
				Assessment Marks	Final		Assessment Marks	Final		
					Duration (Hrs)	Marks		Duration (Hrs)	Marks	
3	1	1.5	5.5	40	3	60	25	-	-	125

Depth Codes

E-Explanation	C-Circuit	D-Definition	DM-Demonstration
DV-Derivation	DW-Drawing	P-Proof	I-Illustration
NUM-Numerical	PRG-Programming	S-State	ACT-Activity-based Learning
MP- Mini Project	EXP-Experiment	REV-Review / Recap	PS- Problem Solving
QA- Question Answer	Q-Quiz	ST- Surprise Test	MT-Mid Term Test

Unit	Topic/Subtopic	Depth Code	Description of Depth	Actual plan			Week
				L	T	P	
1	Introduction						
	1.1 Filter, its evolution and importance	D, E, C	Definition of a filter, filter as a frequency selective two port network, History of filters, Importance of filters in electronics and communication. Applications of filter circuits.	1			
	1.2 Lowpass, highpass, bandpass, bandstop, allpass, passive and active filters	E	Types of filters on the basis of frequency selection: lowpass, highpass, bandpass, bandstop, and allpass filters.	0.5			
	1.3 Filter response: Ideal (Brick wall) response and practical response	E	Ideal and practical response for low pass, high pass, bandpass, bandstop and all pass filters. Reason for non-ideal behavior.	0.5			
	1.4 Filter parameters: Gain, attenuation, passband, stopband and transition band	D, E	Definition and diagrammatic representation of pass band, stop band and transition band. Basic understanding of gain and attenuation of filter circuits in ratio and logarithmic scale. Explanation of pass band, stop band and transition band in terms of gain and attenuation.	1			
	1.5 Filter transfer function, frequency response, poles, zeros and their roles	E	Filter transfer function in s-domain, as the ratio of numerator to denominator polynomial. Factoring numerator polynomial and denominator polynomial to obtain the zeros and poles respectively. Determining filter order from the highest order term of the denominator polynomial. Nature of filter based on location of poles and zeros (for bilinear and biquad transfer functions).	1			
	1.6 Normalization and de-normalization in filter design	E	Definition and practical importance of normalization and de-normalization in	0.5			

Unit	Topic/Subtopic	Depth Code	Description of Depth	Actual plan			Week
				L	T	P	
			filter design.				
	1.7 Impedance (Magnitude) scaling and frequency scaling	D, E, DV, NUM	Concept of impedance scaling and frequency scaling with their applications. Derivation of element scaling equation. Practical applications of scaling with numerical examples.	1.5	1.5		
	Evaluation	QA, Q					

Unit	Topic/Subtopic	Depth Code	Description of Depth	Actual plan			Week
				L	T	P	
2	Approximation Methods						
	2.1 Approximation and its importance in filter design	E	Need of approximation and its importance for realizing practical filters	0.5			
	2.2 Low pass approximations methods	E	Low pass approximations and their features	0.5			
	2.3 Butterworth approximation	D, E, DV, NUM	Magnitude function of Butterworth approximation, its properties, Derivation to calculate the order of Butterworth filter, Calculating the order of Butterworth filter for given lowpass specifications, Determining pole locations and transfer function on the basis of Butterworth filter order.	2	1		
	2.4 Chebyshev (Chebyshev type I) approximation	D, E, DV, NUM	Magnitude function of Chebyshev approximation, its properties, Derivation to calculate the order of Chebyshev filter, Calculating the order of Chebyshev filter for given lowpass specifications, Determining pole locations and transfer function based on the Chebyshev filter order.	2	1		
	2.5 Inverse Chebyshev (Chebyshev type II) approximation	D, E, DV, NUM	Magnitude function of Inverse Chebyshev approximation, its properties, Derivation to calculate the order of Inverse Chebyshev filter, Calculation of the order of Inverse Chebyshev filter for given lowpass specifications, Determining pole/zeros locations.	1.5	1		
	2.6 Cauer (Elliptic) approximation	D, E	Magnitude function for Cauer (or elliptic) approximation, its properties, comparison of Cauer approximation with Butterworth, Chebyshev type I and type II approximations.	0.75			
	2.7 Bessel-Thomson response	D, E, DV	Delay response and its impact. Approximation of constant delay filter, Bessel Thomson response, Storch method, Concept of group delay	1.25			

Unit	Topic/Subtopic	Depth Code	Description of Depth	Actual plan			Week
				L	T	P	
	2.8 Delay equalization	D, E	Concepts of Delay equalization and its importance	0.5			
	Evaluation	QA, Q					

Unit	Topic/Subtopic	Depth Code	Description of Depth	Actual plan			Week
				L	T	P	
3	Frequency Transformation						
	3.1 Frequency transformation and its importance in filter design	D, E	Concept of frequency transformation and its importance in filter design	0.5			
	3.2 Low pass to high pass transformation	E, DV, NUM	Mapping function for Low pass to high pass transformation, Calculation of new element values while applying transformation to given lowpass filter circuit.	0.5	0.5		
	3.3 Low pass to band pass transformation	E, DV, NUM	Mapping function for Low pass to band pass transformation, Calculation of new element values while applying transformation to given lowpass filter circuit.	0.5	0.5		
	3.4 Low pass to band stop transformation	E, DV, NUM	Mapping function for Low pass to band stop transformation, Calculation of new element values while applying transformation to given lowpass filter circuit.	0.5	0.5		
	Evaluation	QA, Q					

Unit	Topic/Subtopic	Depth Code	Description of Depth	Actual plan			Week
				L	T	P	
4	Properties and Synthesis of Passive Networks						
	4.1 One-port passive circuits	D, E, DV, NUM	One-port passive circuits, Properties, Positive real functions. Properties of lossless function, Synthesis of LC one-port circuits, Foster and Cauer realizations. Properties of RC one-port functions (RC-impedance and RC-admittance functions). Synthesis of RC one-port function using Foster and Cauer methods.	0.5 2 1.5	0.5 0.5		
	4.2 Two-port passive circuits	D, E, DV, NUM	Properties of passive two-port circuits, residue condition, Zeros of transmission and their realization. Zero shifting by partial removal of a pole. Synthesis of two port LC and RC ladder circuits based on zero shifting by partial removal of a pole.	1.5 0.5 2	1		

Unit	Topic/Subtopic	Depth Code	Description of Depth	Actual plan			Week
				L	T	P	
	Evaluation	QA, Q					

Unit	Topic/Subtopic	Depth Code	Description of Depth	Actual plan			Week
				L	T	P	
5	Design of Resistively-Terminated Lossless Filters						
	5.1 Properties of resistively-terminated lossless ladder circuit, transmission and reflection coefficients	D, E, DV	Basics of doubly terminated lossless LC ladders, Derivation of expressions for transmission and reflection coefficients, Derivation of driving-point impedance for given t(s) for equal terminations.	1.5			
	5.2 Synthesis of LC ladder circuits to realize all-pole low pass functions and functions with finite transmission zeros	E, DV, NUM	Synthesize a doubly terminated normalized lowpass circuit with equal termination for all-pole function. $ H(j\omega) ^2, R_1, R_2 \rightarrow \rho(j\omega) ^2 \rightarrow$ $\rho(s) \rightarrow Z_m(s) \rightarrow$ Continued fraction expansion \rightarrow Two circuit realizations Concept of realization of doubly terminated LC ladder with finite transmission zeros \Rightarrow using zero shifting by partial removal of a pole. Synthesis of a doubly terminated circuit with unequal termination for all-pole function.	2.5	2		
	Evaluation	QA, Q					

Unit	Topic/Subtopic	Depth Code	Description of Depth	Actual plan			Week
				L	T	P	
6	Design of Active Filters						
	6.1 First order active filters (Bilinear)	D, C, E, DV, NUM	Introduction to active filter with its characteristics. Comparison of active with passive filter. Review of op-amp characteristics, First order active filters (lowpass, highpass) using inverting and non-inverting op-amp configurations.	1	0.5		
	6.2 Second order active filters (Biquads)	E, C, DV, NUM	RLC lowpass filter circuit and its parameters: gain, ω_0 and bandwidth. Tow-Thomas lowpass biquad circuit and transfer function, Highpass, bandpass, bandstop and allpass filter using Tow-Thomas biquad circuit, designing lowpass and bandpass filter circuit using Tow Thomas biquad. Sallen-key lowpass biquad circuit and transfer function. Gain reduction and gain enhancement. Design of a lowpass filter	2.5	1		
				2.5	0.5		

Unit	Topic/Subtopic	Depth Code	Description of Depth	Actual plan			Week
				L	T	P	
			circuit using Sallen-Key biquad. RC-CR transformation.				
	6.3 Higher order active filters	D, E, C, DV, NUM	Techniques for designing higher-order active filters. Cascade of biquads, sequencing of biquad blocks. LC ladder design with simulated inductors. Ideal gyrator, generalized impedance converter (GIC) structure and working. Simulation of grounded and floating inductors, Active simulation of passive filters (up to fifth order) using simulated inductors. LC ladder design using FDNR. Active simulation of passive filters (up to fifth order) using FDNR. Leapfrog simulation of LC ladders (up to fifth order).	0.5 2 1.5 2	0.5 0.5 0.5 0.5		
	Evaluation	QA, Q					

Unit	Topic/Subtopic	Depth Code	Description of Depth	Actual plan			Week
				L	T	P	
7	Sensitivity						
	7.1 Sensitivity and importance of sensitivity analysis	D, E	Definition of sensitivity and its importance	0.25			
	7.2 Single parameter sensitivity	E, DV	Single parameter sensitivity, properties of sensitivity	0.25			
	7.3 Centre frequency and Q-factor sensitivity	E, DV	Definition and derivation of center frequency and Q-factor sensitivity	0.25			
	7.4 Sensitivity of biquads and passive filters	E, DV	Deriving the expressions of sensitivity for RLC lowpass passive filters, Tow Thomas lowpass biquad and Sallen Key lowpass biquad Sensitivity of passive filters	1.25	1		
	Evaluation	QA, Q					

Unit	Topic/Subtopic	Depth Code	Description of Depth	Actual plan			Week
				L	T	P	
8	Other Filters						
	8.1 Switched Capacitor Filters	D, E, DV	Simulation of resistors by switched capacitor, realization of following circuits using switched capacitor Inverting summer, Integrator, Lossy integrator (Refer reference 2)	1			

Unit	Topic/Subtopic	Depth Code	Description of Depth	Actual plan			Week
				L	T	P	
	8.2 Current mode filters	D, E	Basic understanding of current mode signal processing. Using signal current as a control variable as opposed to the signal voltage. (Refer reference 1)	0.25			
	8.3 Adaptive Filters	D, E	Need and basic idea of Adaptive Filters, Applications of adaptive filters (Refer reference 6)	0.25			
	8.4 Current Conveyors	D, E	General introduction of Current Conveyor as a circuit building block, an alternative to operational amplifiers to implement universal filter circuits. (Refer reference 1)	0.5			
	Evaluation	QA, Q					

References:

1. Raut, R., Swamy, M. N. S. (2010). Modern analog filter analysis and design. Wiley-VCH.
2. Schaumann, R., Van Valkenburg, M. E. (2001). Design of analog filters. Oxford University Press.
3. Su, K. L. (2002). Analog filters. Springer.
4. Chen, W. K. (2009). Passive, active and digital filters. CRC Press.
5. Thede, L. D. (2004). Practical analog and digital filter design. Artech House.

Supplementary References:

6. Haykin, S. (2014). Adaptive Filter Theory. Pearson Education
7. Sedra, A.S., Smith, K.C. (2018). Microelectronic Circuits. Oxford University Press.

Filter Design

ENEX 301

Year/Part: III/I

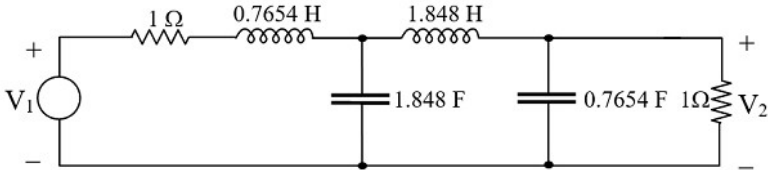
QN	Question	Marks	Unit
1.	<p>a. Why it is not possible to realize the ideal brick wall response in practical filters? Explain. A low pass filter has half power frequency of ω_0 rad/s. Derive the relation to calculate the new value of the resistors, capacitors and inductors present in the low pass filter if you want to change its half power frequency to ω_n rad/s.</p> <p>b. Define filter transfer function. How do you find the order, poles and zeros from the given transfer function?</p>	2+4 3	1
2.	<p>a. What are the characteristics of Inverse Chebyshev response? Derive the expression to calculate the required order of Inverse Chebyshev lowpass filter. Using your expression calculate the required order of Inverse Chebyshev filter for the following lowpass filter specification. $\omega_p = 10000$ rad/s, $\omega_s = 20000$ rad/s, $\alpha_{\max} = 0.4$ dB, $\alpha_{\min} = 16$ dB</p> <p>b. What is delay equalization and how can it be done? Explain with necessary figures.</p>	2+4+2 4	2
3.	<p>a. The following low pass filter has passband frequency ω_p of 1 rad/s. Transform it into a high pass filter having passband frequency of 2 kHz.</p>  <p>b. Explain how resistively terminated ladder network can be realized with finite transmission zeros.</p>	5 4	3 & 5
4.	<p>Which of the following functions are lossless impedance functions? State with reason.</p> <p>i) $\frac{(s^2 + 1).(s^2 + 9)}{(s^2 + 4).(s^2 + 16)}$ ii) $\frac{s(s^2 + 4)}{(s^2 + 1).(s^2 + 3)}$</p> <p>iii) $\frac{2(s^2 + 1).(s^2 + 9)}{s(s^2 + 4)}$ iv) $\frac{s^5 + 4s^3 + 5s}{s^4 + 5s^2 + 6}$</p> <p>Synthesize one of the valid lossless impedance function using Foster I and Cauer I forms.</p>	2+3+3	4
5.	<p>a. Draw the circuit diagram of Tow Thomas biquad filter and derive its lowpass transfer function. Design a second order Butterworth lowpass filter having half power frequency of 5 kHz using Tow Thomas biquad circuit. Your final circuit should have all capacitors of 0.001 μF.</p> <p>b. What is Frequency Dependent Negative Resistor? How can it be used to avoid bulky inductors in the design of filter circuits? Explain with suitable examples.</p> <p>c. Simulate the third order Butterworth low pass filter using Leapfrog</p>	3+4 3 6	6

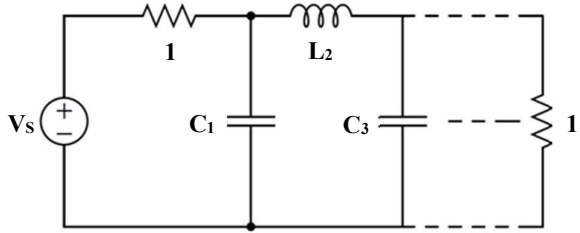
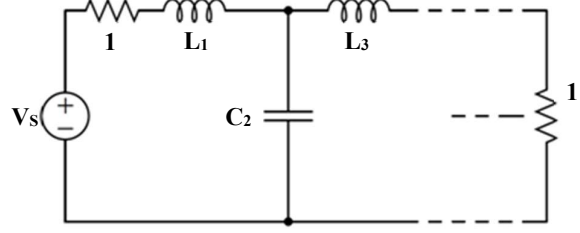
	<p>simulation. Refer following table.</p>  <table border="1" data-bbox="560 441 1023 619"> <thead> <tr> <th>n</th> <th>C_1</th> <th>L_2</th> <th>C_3</th> <th>L_4</th> <th>C_5</th> </tr> </thead> <tbody> <tr> <td>2</td> <td>1.414</td> <td>1.414</td> <td></td> <td></td> <td></td> </tr> <tr> <td>3</td> <td>1</td> <td>2</td> <td>1</td> <td></td> <td></td> </tr> <tr> <td>4</td> <td>0.7654</td> <td>1.848</td> <td>1.848</td> <td>0.7654</td> <td></td> </tr> <tr> <td>5</td> <td>0.618</td> <td>1.618</td> <td>2</td> <td>1.618</td> <td>0.618</td> </tr> </tbody> </table> 	n	C_1	L_2	C_3	L_4	C_5	2	1.414	1.414				3	1	2	1			4	0.7654	1.848	1.848	0.7654		5	0.618	1.618	2	1.618	0.618		
n	C_1	L_2	C_3	L_4	C_5																												
2	1.414	1.414																															
3	1	2	1																														
4	0.7654	1.848	1.848	0.7654																													
5	0.618	1.618	2	1.618	0.618																												
6.	<p>Write short notes on: (any two)</p> <ol style="list-style-type: none"> Sensitivity analysis for Q factor in Tow Tomas lowpass circuit Current conveyor Adaptive filters 	2×3	7 & 8																														

Note: Number of questions and distribution of marks are indicative only.